

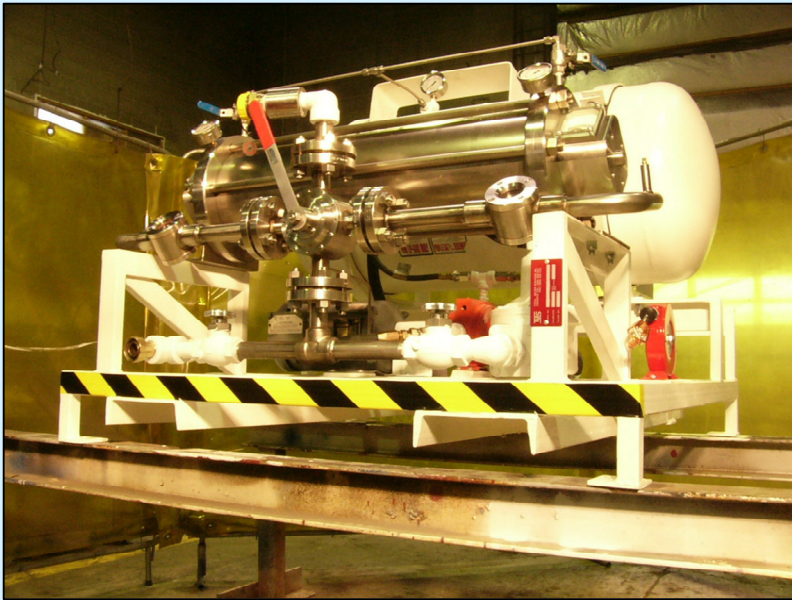

# Total Meter Services Inc.

## Closed Loop Prover



### SPECIFICATIONS

Meets US NIST Standards

Meets Canadian Weights and Measures Standards

**Accuracy & Repeatability:** +/- 0.02%

**Flow Rates:** Minimum 0.25 US Gal (1 Litre)  
Maximum 23 US Gal (90 Litres)

**Op. Press:** Max 300 PSIG

**Weight:** 365 (plus frame, tank & options)

**Dimensions:** 48" W x 48" D x 38" H (fits on standard ½ ton pick up truck)

Patent Pending

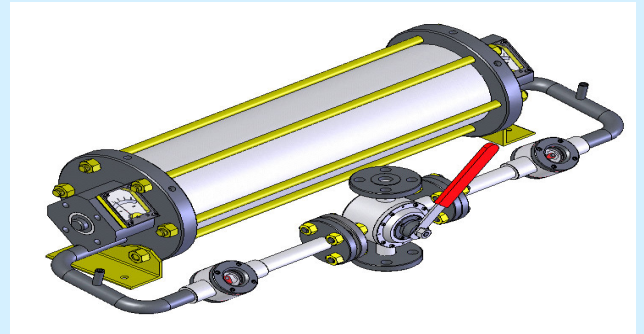

### FEATURES

**CYLINDER:** Honed, Mechanical Grade Steel; Electroless Nickel Plate; Ceramic Interior Finish

**PISTON:** Hard Anodized; Dual Seals; Hydraulic Cushioning

**STROKE INDICATOR:** Magneto/Mechanical

**PRODUCT INLET/RETURN:** 1"

**RETURN TANK:** 180 Litre Pressurized (D.O.T. Approved)

**DUAL SITE FLOW INDICATORS:** Stainless Steel

**PIPING:** 1" SS Schedule 80

**FLANGES:** 300# RF

**PRESSURE GAUGES:** Dual Mechanical

**BLEED VENTS:** Four; 2 Ball Valve; 2 "ORB"

**BONDING CABLE REEL:** 25' Retractable

**FRAME:** Epoxy Primed and Finished; 4 x 4 Base for Pick Up Truck Mounting

**MOUNTING HARDWARE:** SS

**FLOW CONTROL:** SS Manual Four Way Full Stop Diverter Valve with Bleed Port

**RETURN PUMP:** Optional

### KEY BENEFITS

- High ROI
- Simple to Operate
- Compact Design for Portability
- High Repeatability
- No Leveling of Prover Required
- No Zeroing of Prover Required
- No Vapour Loss
- No Draining of Prover Between Runs
- High Durability
- Low Maintenance
- Magnetic/Mechanical Operation (No Power Required)
- Certifiable in Numerous Units of Measure
- Thermowells for ATC
- Flashing Made Inconsequential
- Available in 20 Litre or 60 Litre Capacities

CELEBRATING 25 YEARS OF INNOVATION

FULL TURN-KEY SOLUTIONS